

## PX55 (3.5W max.)

Compact Single Colour LED  
Fountain Light, Constant  
Current



- High power compact spotlight
- Ideal for highlighting fountain jets (IP68)
- Choice of high brightness colours
- Optional mounting sleeve
- Low voltage, high efficiency
- Robust corrosion-resistant construction



## Description

Compact LED fountain light constructed from precision-machined Grade 316 Stainless Steel bezel and hard anodised aluminium housing. Fitted with 3x high brightness Osram LEDs, integral optic and a clear toughened glass lens. Each LED unit is pre-wired with a 1 metre, 2-core cable as standard (other lengths are available). The LED units are *wired in series* and must be connected to a suitable **350mA constant current** power supply.

## Characteristics

### Optical

**Number of LEDs** = 3 High Power LEDs (Osram Oslon)

**Illuminated Area** = Ø25mm

**Optic** = Fitted with Ledil "Satu" optic

#### White LED Data:

Colour	CCT	lm	CRI
Cool White	6,000K	400	75
Mid White	4,000K	350	83
Warm White	2,700K	300	83

Note: Lumen output shown accounts for a 91% optic efficiency.

### Electrical details

**Operating Voltage** = 9.3VDC typ.

**Current** = 0.35A (350mA)

**Power Consumption** = 3.5W max.

Above data is for P969 PCB.

**Termination** = 2-core rubberised tail, 0.75mm<sup>2</sup> CSA, 5.5mm outer diameter (ref: W217)

**Luminaire Classification** = Class III

(In accordance with BS EN 60598-1:2008)

### Mechanical

**Bezel O.D.** = Ø55mm

**Body O.D.** = Ø34mm

**Rear Depth** = 75mm typ. (without optional cable protector)

**Rear Depth** = 93mm typ. (including optional cable protector)

**Lens** = 8mm Stepped Toughened Glass

**IP Rating** = IP68

**Product Weight** = 0.35kg

## Selection Guide

PX55-	S-	W27-	MA-	C-	350-	5M-	GASK
Product Series	Housing	Colour	Optic Type	Lens	Current	Cable Length	Other
PX = LED Fountain Light 55 = Front Bezel Diameter	S = Stainless Steel Bezel & Anodised Aluminium Body	W60 = Cool White W40 = Mid White W27 = Warm White R = Red G = Green B = Blue	NA = Narrow Angle (15°) MA = Medium Angle (25°) WA = Wide Angle (30°)  (other optics including elliptical are available)	C = Clear	350 = 350mA	2M = 2 Metre Cable 5M = 5 Metre Cable  (if a 1 metre cable is fitted, no code needs to be added)	CP = Cable Protector fitted GASK = Silicone gasket (if no accessory is required, no code needs to be added)

**Example PX55-S-W27-NA-C-350** (PX55, Stainless Steel Bezel, 2700K Warm White LED, Narrow Angle, Clear Glass Lens, 350mA, 1 Metre Cable)

# PX55 (3.5W max.)

Compact Single Colour LED  
Fountain Light, Constant  
Current



## Mechanical Details

### PX55 Side View

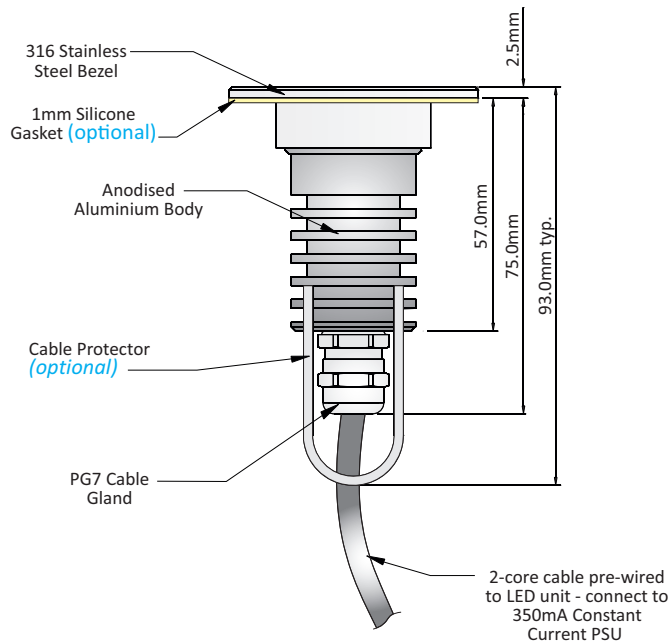

### PX55 Front View

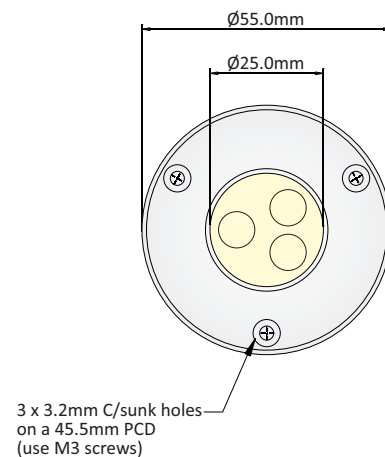

## Mounting Details

### 1) Mounting without Sleeve

For fixing without sleeve, a Ø35.0mm cutout is required, see detail below:-

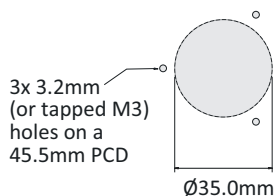

### 2) Mounting with Sleeve

#### i) Top View of Sleeve

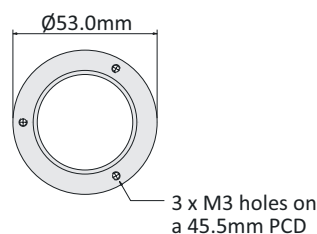

#### ii) Side View of Sleeve

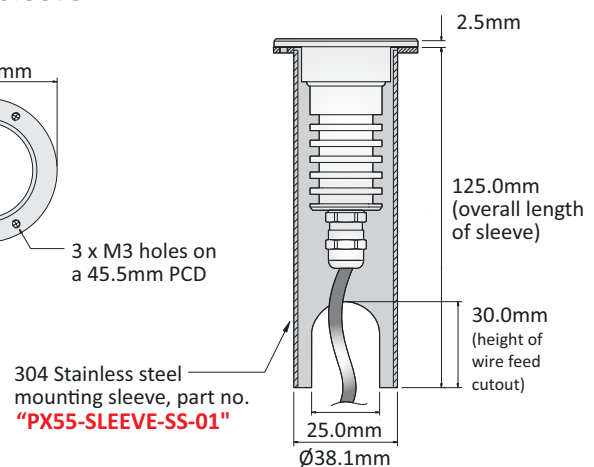

*Mounting Sleeve should be bonded into place with a structural adhesive or mortar.*

The appearance and specifications of the product may be modified for improvement without notice. All dimensions in mm.